

LIBRA H6



HANGERS





SYMBOLS AND FINISHES LEGEND

SYMBOLS

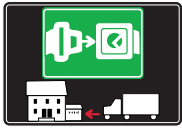

= SHELF SAFELY LOCKED DURING TRANSPORTATION AND AT HOME.



= ANTI-TURNOVER LOCKING SYSTEM



= NORMS / PATENTS



= PHILLIPS / POZIDRIV



= NEWTON



= PART.NO



= HEXAGONAL SOCKET



= FRICTION



= PCS. PER PACKAGE



= BLADE SLOT



= AUTOMATIC



= COMBI SLOT



= DROP DOWN



= CAPACITY LOADING



= COUNTERSUNK HEAD



= WOOD / GLASS THICKNESS



= PAN HEAD



= STANDARD HINGE



= HOLE DIAMETER



= FLANGE HEAD



= KIMANA HINGE



= DIAMETER



= FLAT HEAD



= FLAP HINGE



= LENGTH



= TRILOBULAR SCREW



= WITH SPRING



= HEIGHT



= SELF-TAPPING SCREW



= WITHOUT SPRING



= RIGHT VERSION



= EURO THREAD



= REVERSED SPRING



= LEFT VERSION



= METRIC THREAD



= SETTING CODE



= PRE-INSERTED SCREW



= FOR ROUND TUBE



= PCS. PER PAD



= PRE-INSERTED SCREW AND SPREADING BUSH



= FOR OVAL TUBE



= CUT ON REQUEST



= WITH BUFFER



= SELF ADHESIVE



= WITH MAGNET



= WITH FLANGE

NOTE: Printing errors and omissions may exist despite our best efforts to ensure accuracy. We reserve the right to alter specifications without notice.

MATERIALS

ZA = Zinc Alloy	ST = Steel	HSS = High Speed Steel	BR = Brass	ABS = Acrylonitrile Butadiene Styrene
ZAnk = Nickel-plated Zinc Alloy	STzk = Zinc-plated Steel	AL = Aluminium	WD = Wood	EVA = Ethylene Vinyl Acetate

EP = **ENGINEERING PLASTIC**

+ **EP** = other engineering plastic available on request

SR = **SOFT RUBBER**

+ **SR** = other soft rubber available on request

EPn = Natural Engineering Plastic	EPc = Clear Engineering Plastic	SRn = Natural Soft Rubber
EPw = White Engineering Plastic	EPg = Grey Engineering Plastic	SRw = White Soft Rubber
EPwg = Water Green Engineering Plastic		SRb = Black Soft Rubber



FINISHES



+ **OTHER FINISHES AVAILABLE ON REQUEST**

AA	Natural	JB	Bright Aluminium	QB	Walnut
AB	White	JC	Aluminium - Chrome	RO	Red
AC	Opal White	JD	Matt Aluminium	UZ	T -Met
AE	White 9010	JE	Satin-finished Aluminium	WA	Bronzed
AK	Champagne	JF	Aluminium - Brass	WI	Burnished
AL	Ivory	JG	Aluminium 5	XD	Satin-finished Steel
EA	Black	JL	Aluminium PE 11	YA	Nickel-plated
EB	Glossy Black	JM	Aluminium RAL 9006	YB	Bright Nickel-plated
EC	Matt Black	KA	Chrome	YC	Matt Nickel-plated
EE	Anthracite	KB	Bright Chrome	YD	Satin-finished Nickel-plated
FU	Gunmetal	KC	Matt Chrome	ZA	Zinc alloy
GR	Raw	MA	Brown	ZN	Zinc-plated
HA	Brass-Plated	MB	Light Brown 1	ZQ	Bright Gold
HH	Tropicalized	NN	Metallic Beige	ZY	Titanium
HL	Raw Brass	NO	Beige	ZZ	Clear
IA	Grey	OA	Oak	00	Insignificant finish
IB	Metallic Grey	OZ	Ash		
IF	Middle Grey	PA	Light Ash		
IJ	Light Grey	PZ	Beech		
IL	Grey 20	QA	Maple		

LIBRA H6 LIVING SETTINGS



WALL CABINET APPLICATION

- Capacity loading 120 Kilos per piece (240 Kilos per pair).
- In accordance with the European Regulation DIN 68840.



LIBRA H6

LIBRA H6 is the latest development in the cabinet hangers program offered by Italiana Ferramenta.

The **LIBRA** hangers are to be installed behind the rear panel with the only small cover caps left visible inside the cabinet.

LIBRA is a very resistant and reliable solution as the zinc alloy body is sensibly thicker, and therefore stronger.

All the models within the **LIBRA** family feature an innovative **ANTI-TURNOVER** device which is covered by patent.

LIBRA H6 is the left/right cabinet hanger with 2 semi-circular pins Ø15mm + pre-inserted screw for the top (if required).

It features an innovative locking device to the side panel conceived to sensibly increase the capacity loading of the cabinet.

The axial-locking of **LIBRA H6** allows the fixing screw to penetrate the side panel beyond the back panel groove.

Also featured in the **LIBRA** family are 5 types of wall plates and 1 types of wall bars made of very thick zinc-coated steel and hardened by punched impressions.

Wall bars and wall plates feature oval holes which facilitate

the correct positioning and give the possibility to carry out the horizontal adjustment.

Placement of the holes for wall-fixation has been optimised to reduce the stress on the plates and on the plugs.

LIBRA cabinet hangers allow to adjust the cabinet vertically and horizontally. The 2 movements are 100% **INDEPENDENT** of each other and therefore make the adjustments much easier and more efficient.

The adjustment and the locking of the **ANTI-TURNOVER** bolt can be carried out from the inside of the cabinet by using a standard PZ2 screwdriver.

Steel, Zinc alloy and Engineering plastic according to related version.

PAT. PENDING



INSTALLATION UNDER THE CABINET TOP

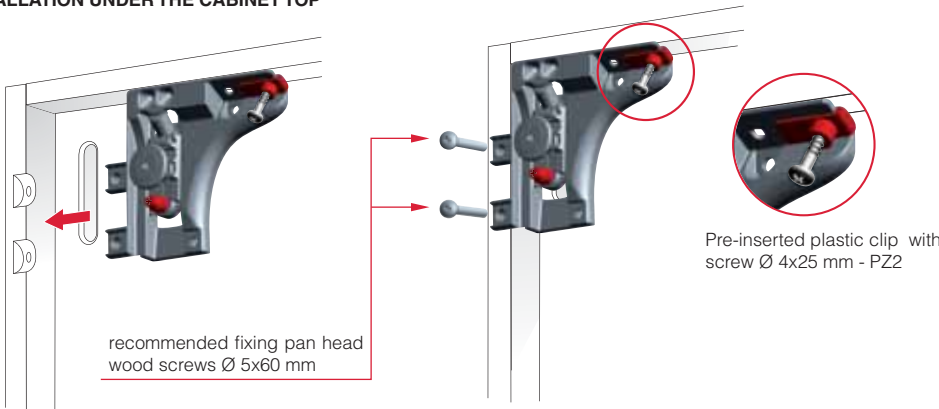

INSTALLATION ON THE WALL

- For details refer to "LIBRA WALL PLATES: LIBRA WP5"



COVER CAP INSERTING

- For details refer to "LIBRA COVER CAPS"

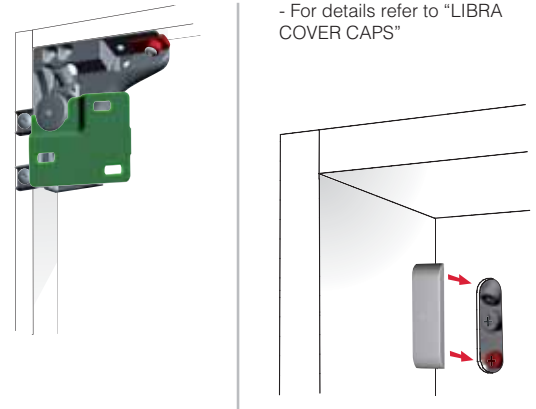

It is the responsibility of the customer:

- to ensure that the wall is of a suitable quality to hold the unit fixing in place.
- to use the proper hardware fittings according to the construction of the wall.

For more specific information, please refer to the WARNINGS section at the end of the catalogue.

ADJUSTMENTS

1
VERTICAL ADJUSTMENT
13 mm

2
IN-DEPTH ADJUSTMENT
12 mm

3
ANTI-TURNOVER LOCKING
Stop screwing the red bolt when it touches the wall plate

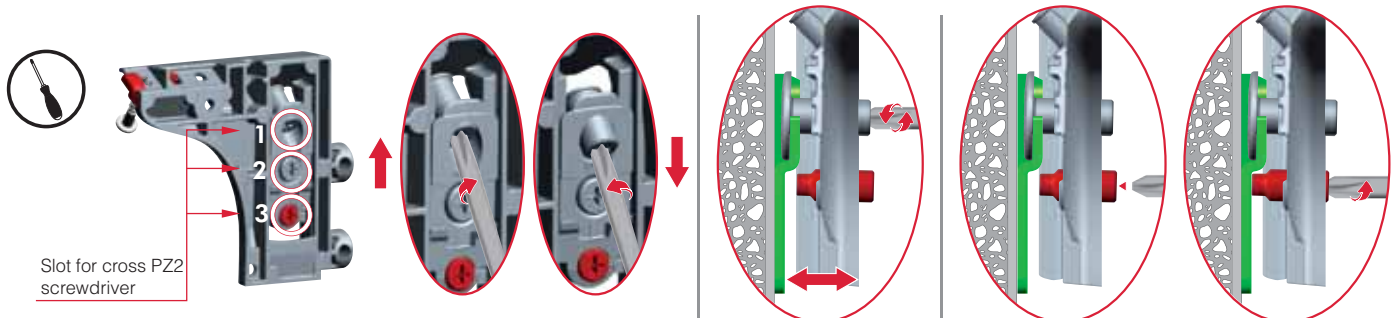

**DRILLING PLAN FOR LIBRA H6
SIDE PANEL AND SERVICE GAP**

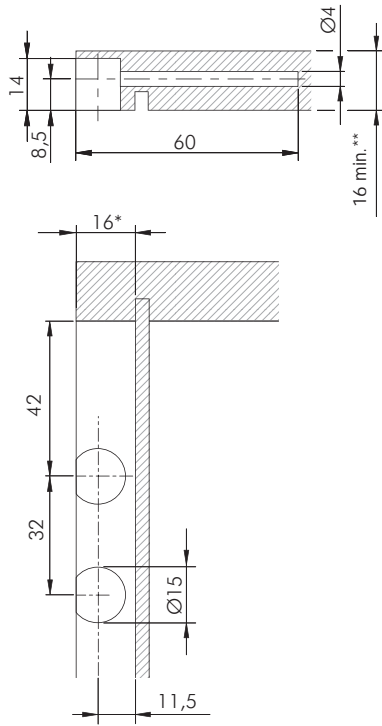

BACK PANEL

Libra CC1-CC4-CC5 cover cap

Libra CC2 cover cap

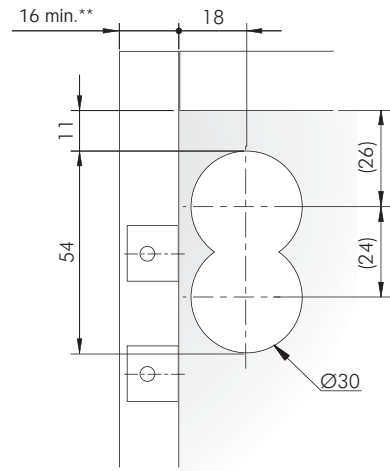
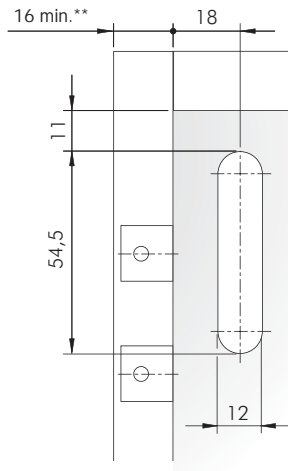

* Our technical department is at your disposal for different service gap options.

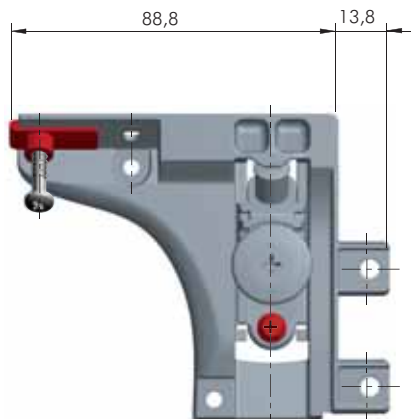
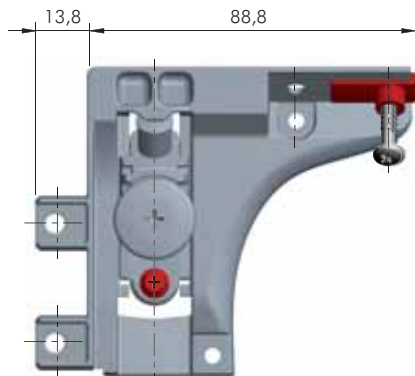

= PZ2

ZA ST

= 50 pcs.



63420500ZN

R

63420510ZN

L



LIBRA H6 SPACER - 1 mm

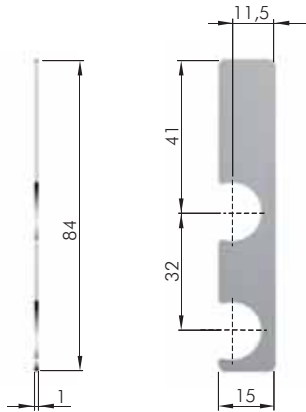
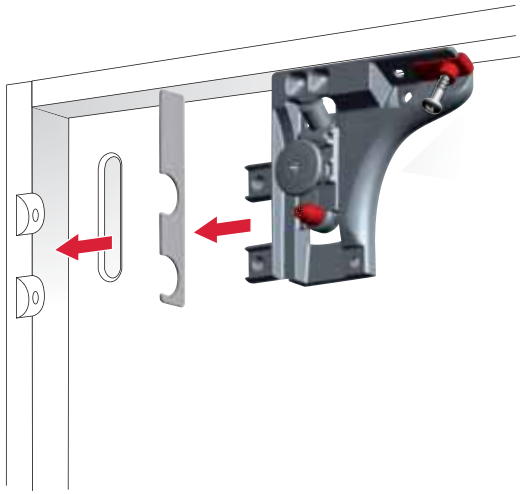

ST	= on request
123	
63490510XE	

LIBRA H6 FIXING ACCESSORY

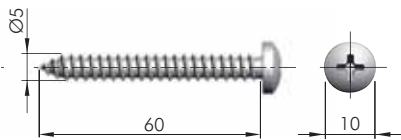

= Ø 4 mm	
= PZ2	
ST	= 200 pcs.
123	
60103560ZN	

LIBRA H6 and LIBRA CH APPLICATIONS

BENEFITS OF LIBRA H6 AND LIBRA CH HANGING SYSTEMS:

- Vertical and in-depth adjustments, as well as the locking of the cabinet, can be easily and smoothly carried out from the inside.
- The hanging system is never interfering with the slides for drawers as it is placed behind the back panel.
- Absolutely no mills, drillings or grooves required inside the cabinet.

In the **current absence of a unifying European norm** which sets the standards for testing procedures aimed at defining capacity loadings of hanging systems conceived for suspended base units, we Italiana Ferramenta have simulated some of the most critical scenarios. The following simulations are meant to give our customers valid reference points concerning cabinet dimensions, weights, recommended loading capacity even when loaded drawers are opened.

The reported data, empirically obtained, exclusively refer to the constructions and examples shown, correctly positioned and assembled by using WP5 wall plate.

The customer must ensure that the wall is of suitable quality and structure.

Other important factors to be taken into consideration are determined by:

- the type of side panel, the actual thickness and the material used. It is recommended to use chipboard panels. For MDF panels please contact us for further information concerning the screw fixing.
- the type and dimensions of the screws used.
- the actual positioning, depth and width of the groove milled for the back side installation.
- the capacity loading of the drawer slides used as well as the actual construction of the drawer.

We always recommend to test a complete cabinet.

For cases which differ from the ones reported, please contact us.

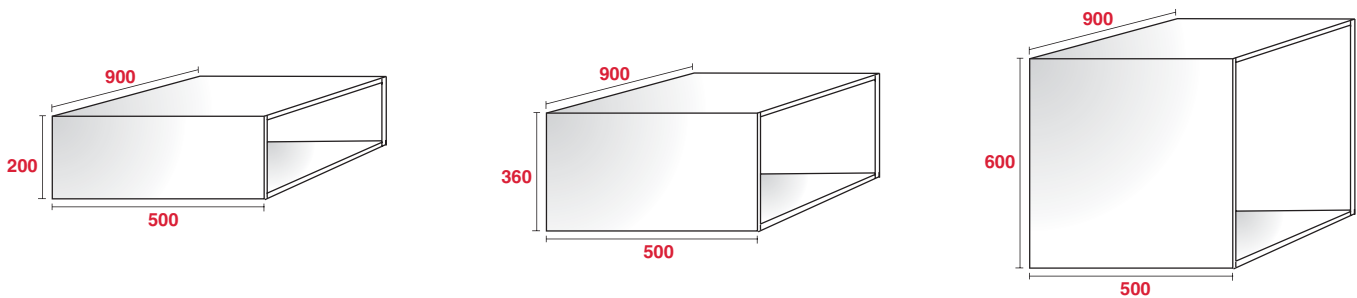

FURNITURE TYPE	CAPACITY LOADING	
	LIBRA H6	LIBRA H6 + 1 LIBRA CH
Cabinet	100 Kg	150 Kg
Cabinet + drawer	70 Kg + 30 Kg	120 Kg + 30 Kg

FURNITURE TYPE	CAPACITY LOADING	
	LIBRA H6	LIBRA H6 + 1 LIBRA CH
Cabinet	180 Kg	230 Kg
Cabinet + drawer	150 Kg + 30 Kg	180 Kg + 50 Kg

FURNITURE TYPE	CAPACITY LOADING	
	LIBRA H6	LIBRA H6 + 1 LIBRA CH
Cabinet	200 Kg	230 Kg
Cabinet + drawer	170 Kg + 30 Kg	170 Kg + 50 Kg

The reported data, empirically obtained, exclusively refer to the constructions and examples shown, correctly positioned and assembled by using WP5 wall plate.

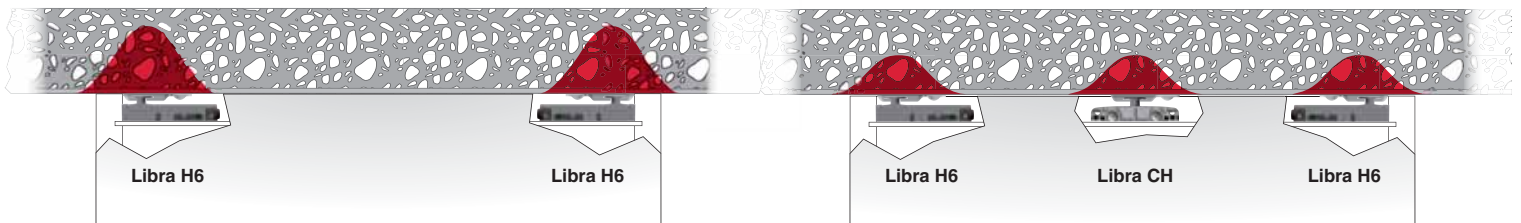
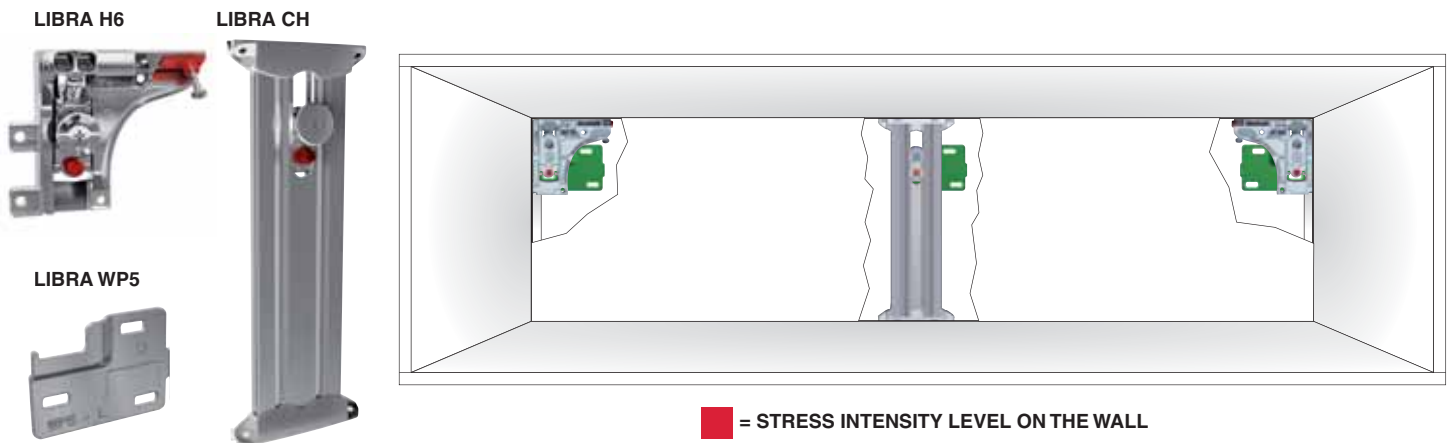

By adding Libra CH to Libra H6, the capacity loading is more evenly distributed, thus sensibly reducing the stress intensity level on the wall.



DEMONSTRATION SCHEME : WHERE AND HOW TO USE LIBRA H6 AND LIBRA CH

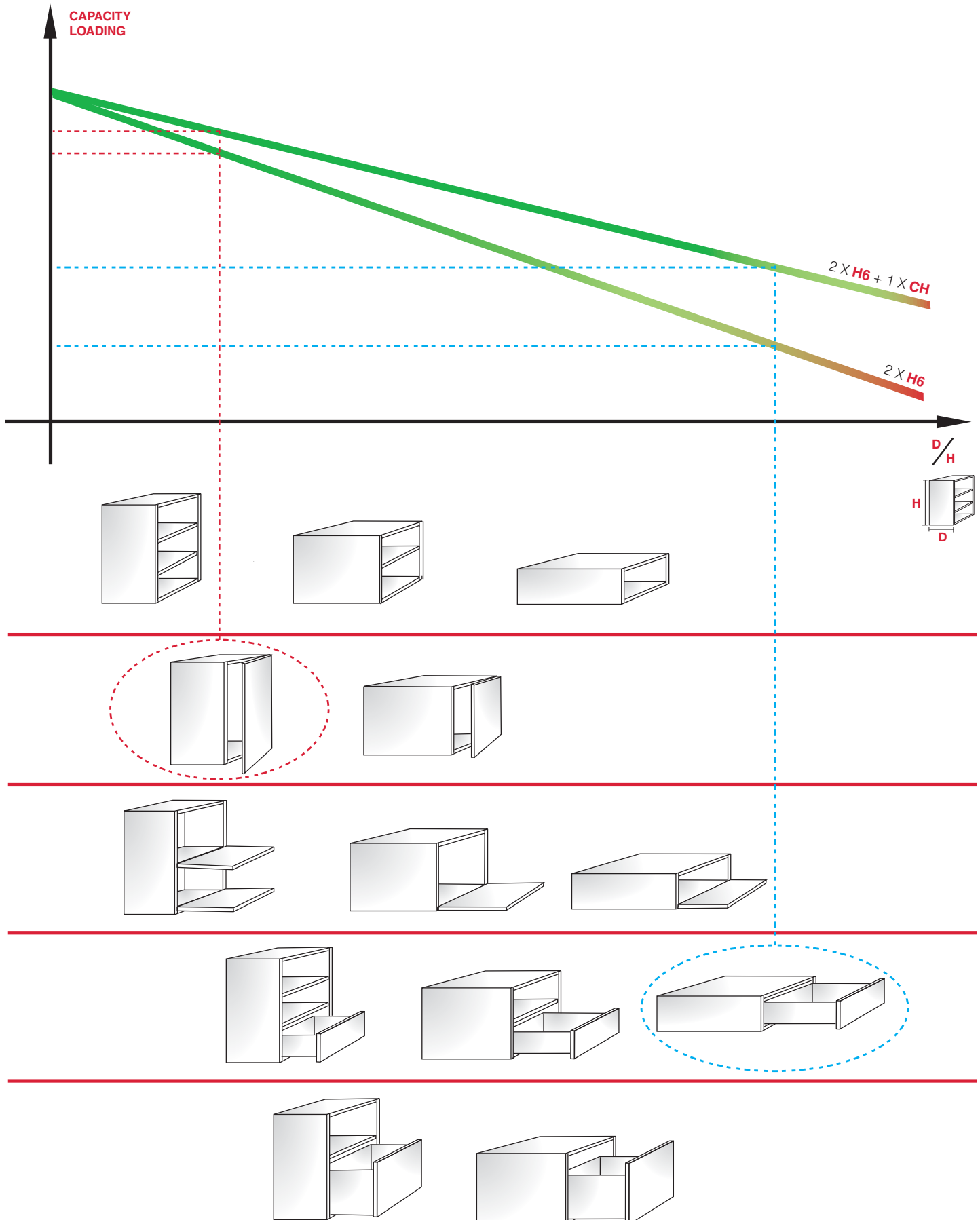

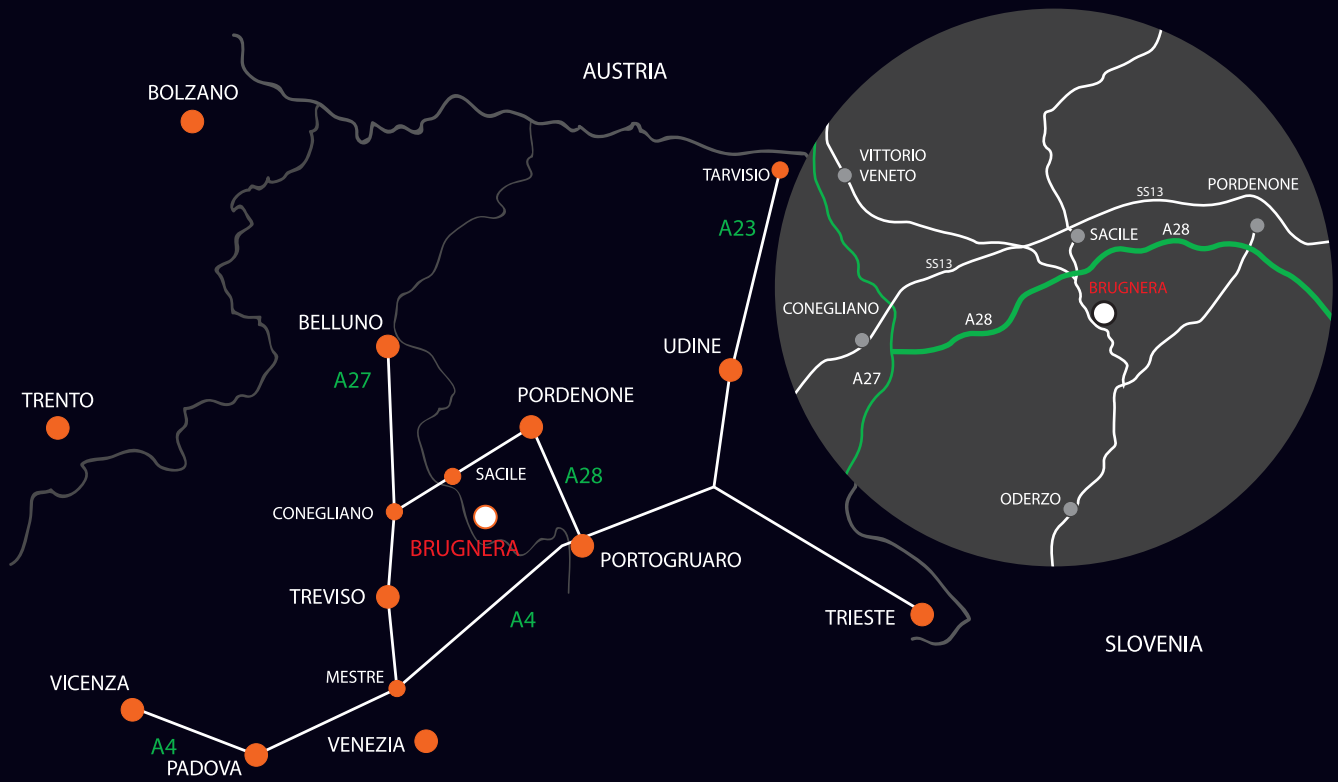

www.italianaferramenta.com